



**REQUEST FOR QUOTATION**  
**For**  
**“TYBEE PIER STAIR REPLACEMENT”**  
**QUOTE NUMBER: 14-0025-4**

The Number Must Appear On All Quotations and Related Correspondence.

**Quotation must be received NOT LATER THAN 2:00 PM, on March 31, 2014 at the office of the Purchasing Agent. Quotes may be faxed, emailed, mailed or hand delivered.**

**Address Reply To: Robert Marshall , 912-790-1622**

**Mail to: 1117 Eisenhower Drive Suite C Savannah Georgia 31406**

**Fax to: 912 -790-1627**

**Email to: rmarshall@chathamcounty.org**

**NAME OF BIDDER:** \_\_\_\_\_

**STREET ADDRESS:** \_\_\_\_\_

**CITY, STATE, ZIP CODE:** \_\_\_\_\_

**PHONE:** \_\_\_\_\_ **FAX:** \_\_\_\_\_

**EMAIL:** \_\_\_\_\_ **FED TAX ID #:** \_\_\_\_\_

INDICATE MINORITY OWNERSHIP STATUS OF BIDDER (FOR STATISTICAL PURPOSES ONLY):

CHECK ONE:

\_\_\_\_\_ NON-MINORITY OWNED

\_\_\_\_\_ AFRICAN AMERICAN

\_\_\_\_\_ HISPANIC

\_\_\_\_\_ ASIAN AMERICAN

\_\_\_\_\_ AMERICAN INDIAN

\_\_\_\_\_ WOMAN

The purpose of this request is to obtain services of a qualified contractor for the replacement of stairs at the Tybee Pier located on Tybee Island, Georgia.

**All work shall be performed as shown on the attached Plan Sheet/Plan Sheet notes prepared by Thomas & Hutton. Plan Sheet notes include all technical specifications for this project. No additional specifications are available.**

***PROJECT DESCRIPTION  
TYBEE PIER & PAVILION  
STAIR REPLACEMENT***

**The Project Scope consists of the replacement of the existing timber stairs providing pedestrian access from the beach to the pier structure oceanside of the Pavilion. The stairs are widely used by the public to access the pier during private functions or events being held at the Pavilion.**

**The work will include the demolition of the existing stair system in its entirety and the construction of a new timber stairway including installation of new light fixtures on the stair railing along with an overhead light and shower at the beach entrance to the stairway. The new lights are to be re-connected to the existing electrical services currently in place.**

**During the demolition and construction of the Pavilion will remain in use by the public. The contractor is to provide safety measures during his work on the stairway to protect the public at the stair entrance location on the pier.**

**Special Conditions**

1. Work shall be performed during normal working hours, 7:00 a.m. - 7:00 p.m. Monday – Sunday.

For any questions regarding the Request for Quote, please contact Robert Marshall, Senior Procurement Specialist, at 912-790-1622. **For any work related/technical questions please contact the Project Manager, Lorenzo Bryant at 912-652-6783.**

Description	LUMP SUM PRICE
TYBEE PIER STAIR REPLACEMENT	\$

**COMMENCEMENT AND COMPLETION:**

**WORK SHALL BEGIN WITHIN 10 DAYS AFTER RECEIPT OF "NOTICE TO PROCEED". ALL WORK SHALL BE COMPLETED WITHIN 60 CALENDAR DAYS AFTER THE TEN DAY PERIOD.**

\_\_\_\_\_  
Please Print Name

\_\_\_\_\_  
Authorization Signature

\_\_\_\_\_  
Company

\_\_\_\_\_  
Address

\_\_\_\_\_  
Phone / Fax No's.

\_\_\_\_\_  
Email

Date \_\_\_\_\_

## Request for Quotation Instructions

1. **Quote must be submitted on sheets provided in spaces indicated.**
2. All information required by request for quotation must be completed to constitute a proper bid.
3. Contractor warrants that the goods are merchantable and as described herein or in the solicitation response. Additional warranties may be called for in the specifications.
4. Chatham County is exempt, by law, from any and all federal and state taxes. Do not include taxes in your quotations. Tax exemption number is **58-6001113**. Exemption certificate will be provided upon request.
5. Price Protection Period of sixty (60) days for all items desired from date of bid opening. Vendors are advised that prices in effect at time of bid shall apply and not be subject to revision at time of shipment.
6. **Minority/Women Business Enterprise (MWBE) Policy:** It is the policy of the County to provide minority and women owned business enterprises with equal opportunity for participating in selling goods and services to the County.
7. A copy of your current business license shall be submitted with your quote.
8. **Insurance Provisions:** The selected Contractor shall be required to procure and maintain for the duration of the contract insurance against claims for injuries to persons or damages to property which may arise from or in connection with the performance of the work hereunder by the Contractor, his agents, representatives, employees or subcontractors. The cost of such insurance shall be included in the Quote. **Contract work will not proceed unless Chatham County has in their possession, a current Certificate of Insurance.**
9. **Employment Eligibility Verification:** As required under Senate Bill 529 – “Georgia Security and Immigration Compliance Act” of 2006, O.C.G.A. Section 2, Article 3 13-10-91, public employers, their contractors and subcontractors are required to verify the work eligibility of all newly hired employees through an electronic federal work authorization program. The Georgia Department of Labor has added a new Chapter 300-10-1, entitled "Public Employers, Their Contractors and Subcontractors Required to Verify New Employee Work Eligibility Through a Federal Work Authorization Program," to the Rules and Regulations of the State of Georgia. (See website: [http://www.dol.state.ga.us/pdf/rules/300\\_10\\_1.pdf](http://www.dol.state.ga.us/pdf/rules/300_10_1.pdf).) The new rules designate the “Employment Eligibility Verification (EEV) Basic Pilot Program” operated by the U.S. Citizenship and Immigration Services Bureau of the U.S. Department of Homeland Security as the electronic federal work authorization program to be utilized for these purposes. The EEV/Basic Pilot Program can be accessed at: <https://e-verify.uscis.gov/enroll/StartPage.aspx?JS=YES>. Bidders shall comply with this new rule and submit with your bid the attached “Contractor Affidavit and Agreement.”
10. O.C.G.A. § 50-36-1, requires Georgia’s cities to comply with the federal **Systematic Alien Verification for Entitlements (SAVE) Program**. SAVE is a federal program used to verify that applicants for certain “public benefits” are legally present in the United States. Contracts with the County are considered “public benefits.” Therefore, the bidders are required to provide the Affidavit Verifying Status for Chatham County Benefit Application prior to receiving any County contract. The affidavit is included as part of this bid package.
11. The original invoice is to be submitted to the County Finance Department. The purchase order number must be shown on all invoices and packing lists.
12. References may be requested of the successful bidder.

ATTACHMENT A

**DRUG - FREE WORKPLACE CERTIFICATION**

THE UNDERSIGNED CERTIFIES THAT THE PROVISIONS OF CODE SECTIONS 50-24-1 THROUGH 50-24-6 OF THE OFFICIAL CODE TO GEORGIA ANNOTATED, RELATED TO THE **\*\*DRUG-FREE WORKPLACE\*\***, HAVE BEEN COMPLIED WITH IN FULL. THE UNDERSIGNED FURTHER CERTIFIES THAT:

1. A Drug-Free Workplace will be provided for the employees during the performance of the contract; and
2. Each sub-contractor under the direction of the Contractor shall secure the following written certification:

\_\_\_\_\_ (CONTRACTOR) certifies to Chatham County that a Drug-Free Workplace will be provided for the employees during the performance of this contract known as \_\_\_\_\_

—  
(PROJECT) pursuant to paragraph (7) of subsection (B) of Code Section 50-24-3. Also, the undersigned further certifies that he/she will not engage in the unlawful manufacture, sale, distribution, possession, or use of a controlled substance or marijuana during the performance of the contract.

\_\_\_\_\_  
CONTRACTOR

\_\_\_\_\_  
DATE

\_\_\_\_\_  
NOTARY

\_\_\_\_\_  
DATE

**ATTACHMENT B**

**PROMISE OF NON-DISCRIMINATION STATEMENT**

Know All Men By These Presence, that I (We), \_\_\_\_\_,  
Name  
\_\_\_\_\_ (herein after  
"Company"),  
Title \_\_\_\_\_ Name of Bidder  
in consideration of the privilege to bid/or propose on the following Chatham  
County project procurement \_\_\_\_\_  
\_\_\_\_\_ hereby consent, covenant and agree as follows:

(1) No person shall be excluded from participation in, denied the benefit of or otherwise discriminated against on the basis of race, color, national origin or gender in connection with the bid submitted to Chatham County or the performance of the contract resulting therefrom;

(2) That it is and shall be the policy of this Company to provide equal opportunity to all business persons seeking to contract or otherwise interested with the Company, including those companies owned and controlled by racial minorities, and women;

(3) In connection herewith, I (We) acknowledge and warrant that this Company has been made aware of, understands and agrees to take affirmative action to provide minority and women owned companies with the maximum practicable opportunities to do business with this Company on this contract;

(4) That the promises of non-discrimination as made and set forth herein shall be continuing throughout the duration of this contract with Chatham County;

(5) That the promises of non-discrimination as made and set forth herein shall be and are hereby deemed to be made a part of and incorporated by reference in the contract which this Company may be awarded;

(6) That the failure of this Company to satisfactorily discharge any of the promises of non-discrimination as made and set forth above may constitute a material breach of contract entitling the County to declare the contract in default and to exercise appropriate remedies including but not limited to termination of the contract.

\_\_\_\_\_  
Signature

\_\_\_\_\_  
Date

**Attachment C**

**CONTRACTOR AFFIDAVIT AND AGREEMENT**

By executing this affidavit, the undersigned contractor verifies its compliance with O.C.G.A.13-10-91, stating affirmatively that the individual, firm, or corporation which is contracting with (name of public employer) has registered with and is participating in a federal work authorization program\* [any of the electronic verification of work authorization programs operated by the United States Department of Homeland Security or any equivalent federal work authorization program operated by the United States Department of Homeland Security to verify information of newly hired employees, pursuant to the Immigration Reform and Control Act of 1986 (IRCA), P.L. 99-603], in accordance with the applicability provisions and deadlines established in O.C.G.A. 13-10-91.

The undersigned further agrees that, should it employ or contract with any subcontractor(s) in connection with the physical performance of services pursuant to this contract with (name of public employer), contractor will secure from such subcontractor(s) similar verification of compliance with O.C.G.A. 13-10-91 on the Subcontractor Affidavit provided in Rule 300-10-01-08 or a substantially similar form. Contractor further agrees to maintain records of such compliance and provide a copy of each such verification to the (name of the public employer) at the time the subcontractor(s) is retained to perform such service.

\_\_\_\_\_  
EEV / Basic Pilot Program\* User Identification Number

\_\_\_\_\_  
BY: Authorized Officer or Agent  
(Contractor Name)

\_\_\_\_\_  
Date

\_\_\_\_\_  
Title of Authorized Officer or Agent of Contractor

\_\_\_\_\_  
Printed Name of Authorized Officer or Agent

SUBSCRIBED AND SWORN  
BEFORE ME ON THIS THE  
\_\_\_\_ DAY OF \_\_\_\_\_, 20\_\_\_\_

\_\_\_\_\_  
Notary Public

My Commission Expires:

\_\_\_\_\_  
\* As of the effective date of O.C.G.A. 13-10-91, the applicable federal work authorization program is the "EEV / Basic Pilot Program" operated by the U. S. Citizenship and Immigration Services Bureau of the U.S. Department of Homeland Security, in conjunction with the Social Security Administration (SSA).

**Attachment D**

**SUBCONTRACTOR AFFIDAVIT**

By executing this affidavit, the undersigned subcontractor verifies its compliance with O.C.G.A. 13-10-91, stating affirmatively that the individual, firm or corporation which is engaged in the physical performance of services under a contract with (name of contractor) on behalf of (name of public employer) has registered with and is participating in a federal work authorization program\* [any of the electronic verification of work authorization programs operated by the United States Department of Homeland Security or any equivalent federal work authorization program operated by the United States Department of Homeland Security to verify information of newly hired employees, pursuant to the Immigration Reform and Control Act of 1986 (IRCA), P.L. 99-603], in accordance with the applicability provisions and deadlines established in O.C.G.A. 13-10-91.

\_\_\_\_\_  
EEV / Basic Pilot Program\* User Identification Number

BY:

(Subcontractor Name)

\_\_\_\_\_  
Authorized Officer or Agent

Date

\_\_\_\_\_  
Title of Authorized Officer or Agent of Subcontractor

\_\_\_\_\_  
Printed Name of Authorized Officer or Agent

SUBSCRIBED AND SWORN

BEFORE ME ON THIS THE

\_\_\_\_ DAY OF \_\_\_\_\_, 20\_\_

\_\_\_\_\_  
Notary Public

My Commission Expires:

\_\_\_\_\_  
\* As of the effective date of O.C.G.A. 13-10-91, the applicable federal work authorization program is the "EEV / Basic Pilot Program" operated by the U. S. Citizenship and Immigration Services Bureau of the U.S. Department of Homeland Security, in conjunction with the Social Security Administration (SSA).



Attachment E

***Systematic Alien Verification for Entitlements (SAVE)  
Affidavit Verifying Status for Chatham County Benefit Application***

By executing this affidavit under oath, as an applicant for a Chatham County, Georgia Business License or Occupation Tax Certificate, Alcohol License, Taxi Permit, Contract or other public benefit as reference in O.C.G.A. Section 50-36-1, I am stating the following with respect to my bid for a Chatham County contract for \_\_\_\_\_. [Name of natural person applying on behalf of individual, business, corporation, partnership, or other private entity]

1.) \_\_\_\_\_ I am a citizen of the United States.

**OR**

2.) \_\_\_\_\_ I am a legal permanent resident 18 years of age or older.

**OR**

3.) \_\_\_\_\_ I am an otherwise qualified alien (8 § USC 1641) or non-immigrant under the Federal Immigration and Nationality Act (8 USC 1101 et seq.) 18 years of age or older and lawfully present in the United States.\*

In making the above representation under oath, I understand that any person who knowingly and willfully makes a false, fictitious, or fraudulent statement or representation in an affidavit shall be guilty of a violation of Code Section 16-10-20 of the Official Code of Georgia.

Signature of  
Applicant:  
Date

\_\_\_\_\_  
Printed Name:

\* \_\_\_\_\_  
Alien Registration number for non-citizens.

SUBSCRIBED AND SWORN  
BEFORE ME ON THIS THE  
\_\_\_\_ DAY OF \_\_\_\_\_, 20 \_\_\_\_

Notary Public  
My Commission Expires:

**ATTACHMENT F**

**CHATHAM COUNTY, GEORGIA**

**BIDDER'S CERTIFICATION REGARDING DEBARMENT, SUSPENSION, INELIGIBILITY  
AND VOLUNTARY EXCLUSION**

The undersigned certifies, by submission of this proposal or acceptance of this contract, that neither Contractor nor its principals is presently debarred, suspended, proposed for debarment, declared ineligible, or voluntary excluded from participation in this transaction by any Federal department or agency, State of Georgia, City of Savannah, Board of Education or local municipality. Bidder agrees that by submitting this proposal that Bidder will include this clause without modification in all lower tier transactions, solicitations, proposals, contracts and subcontracts. Where the Bidder or any lower tier participant is unable to certify to this statement, that participant shall attach an explanation to this document.

Bidder must verify Sub-Tier Contractors and Suppliers are not debarred, suspended, ineligible, pending County litigation or pending actions from any of the above government entities.

**Certification - the above information is true and complete to the best of my knowledge and belief.**

\_\_\_\_\_  
(Printed or typed Name of Signatory)

\_\_\_\_\_  
(Signature)

\_\_\_\_\_  
(Date)

**NOTE:** The penalty for making false statements in offers is prescribed in 18 U.S.C. 1001

\_\_\_\_\_  
**END OF DOCUMENT Mod. CC P & C 6/2005**

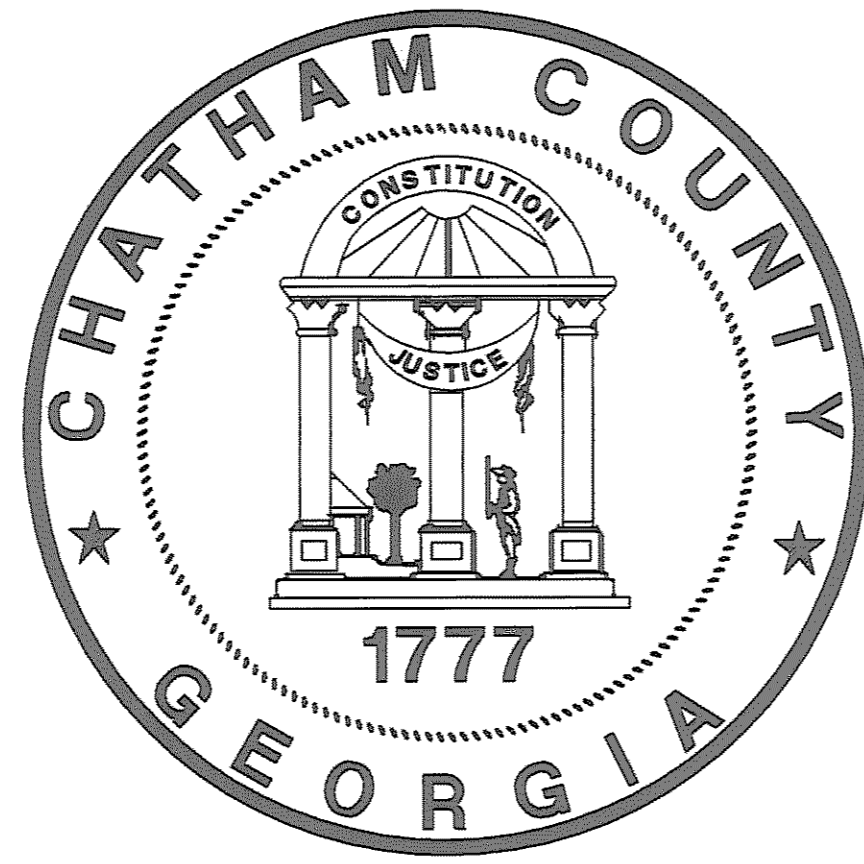

# TYBEE PIER STAIR REPLACEMENT

PREPARED FOR:  
CHATHAM COUNTY PUBLIC WORKS  
CHATHAM COUNTY, GEORGIA

OCTOBER 2013  
ISSUED FOR BIDS

J-23492

PREPARED BY:

**TH** **THOMAS & HUTTON**  
Engineering | Surveying | Planning | GIS | Consulting

Savannah, GA | Brunswick, GA | Charleston, SC | Myrtle Beach, SC | Wilmington, NC

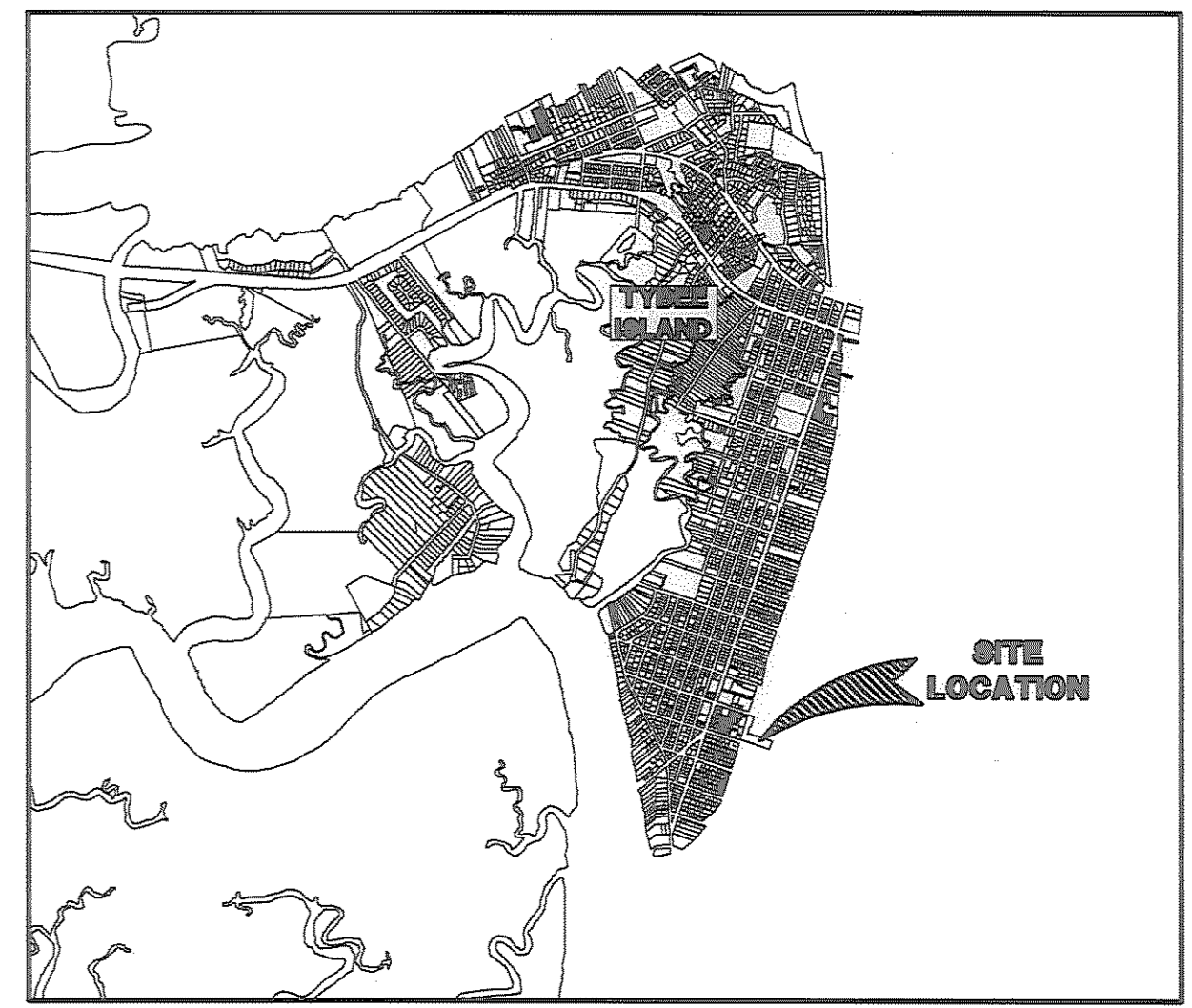
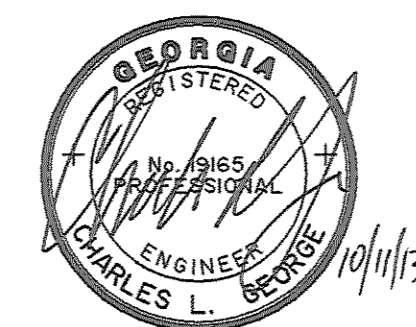

VICINITY MAP

J-23492  
OCTOBER 2013  
TYBEE PIER  
STAIR REPLACEMENT

### SCHEDULE OF DRAWINGS

SHEET NO.	DESCRIPTION
S0.0	COVER SHEET
S0.1	GENERAL NOTES
S1.1	EXISTING LAYOUT
S1.2	PROPOSED LAYOUT
S2.1	FRAMING PLAN
S3.1	SECTIONS AND DETAILS

### REVISION HISTORY

REV. NO.	REVISION	BY	DATE

### SUBMITTAL HISTORY

SUBMITTED TO	DATE



Know what's below.  
Call before you dig.

**TH THOMAS & HUTTON**  
Engineering | Surveying | Planning | GIS | Consulting  
50 Park of Commerce Way  
PO Box 2727  
Savannah, GA 31402-2727  
p.912.234.5300 f.912.234.2950  
www.thomashutton.com

1.00 **GENERAL**

- 1.01 THE DRAWINGS CONTAINED IN THIS SET ARE THE PROPERTY OF THOMAS & HUTTON ENGINEERING CO. AND ARE NOT TO BE COPIED OR REPRODUCED IN WHOLE OR IN PART. THESE DRAWINGS ARE ONLY TO BE USED FOR THE PROJECT AND SITE SPECIFICALLY IDENTIFIED HEREIN AND ARE NOT TO BE USED ON ANY OTHER PROJECT WITHOUT WRITTEN PERMISSION FROM THE ENGINEER OF RECORD.
- 1.02 ALL CONSTRUCTION SHALL CONFORM TO THE INTERNATIONAL BUILDING CODE 2006 EDITION. REFERENCE TO OTHER STANDARD SPECIFICATIONS OR CODES SHALL MEAN THE LATEST STANDARD OR CODE ADOPTED AND PUBLISHED.
- 1.03 DRAWINGS SHOW TYPICAL AND CERTAIN SPECIFIC CONDITIONS ONLY. FOR DETAILS NOT SPECIFICALLY SHOWN PROVIDE DETAILS SIMILAR TO THOSE SHOWN.
- 1.04 VERIFY ALL EXISTING CONDITIONS, DIMENSIONS AND ELEVATIONS BEFORE STARTING WORK. NOTIFY THE ENGINEER OF ANY DISCREPANCY.
- 1.05 NOTIFY THE ENGINEER OF CONDITIONS ENCOUNTERED IN THE FIELD CONTRADICTORY TO THOSE SHOWN ON THE CONTRACT DOCUMENTS.
- 1.06 THE CONTRACTOR IS SOLELY RESPONSIBLE FOR THE DESIGN, ADEQUACY, AND SAFETY OF ERECTION BRACING, SHORING, TEMPORARY SUPPORTS, ETC. THE STRUCTURAL ELEMENTS ARE NOT STABLE UNTIL THE STRUCTURE IS COMPLETE.
- 1.07 THE CONTRACTOR IS RESPONSIBLE FOR COORDINATION OF DIMENSIONS SHOWN ON THE STRUCTURAL PLAN AND DETAIL DRAWINGS. NOTIFY THE ENGINEER OF ANY DISCREPANCY BEFORE STARTING SHOP DRAWINGS OR ANY WORK. FOR DIMENSIONS NOT SHOWN, SEE CIVIL DRAWINGS.
- 1.08 REVIEW OF SHOP DRAWINGS AND OTHER SUBMITTALS BY THE ENGINEER DOES NOT RELIEVE THE CONTRACTOR OF THE RESPONSIBILITY TO REVIEW AND CHECK SHOP DRAWINGS BEFORE SUBMITTAL TO THE ENGINEER. THE CONTRACTOR REMAINS SOLELY RESPONSIBLE FOR ERRORS AND OMISSIONS ASSOCIATED WITH THE DIMENSIONS SPECIFIED IN THE CONTRACT DOCUMENTS. CONTRACTOR IS ALSO RESPONSIBLE FOR THE MEANS, METHODS, TECHNIQUES, SEQUENCES, AND PROCEDURES OF CONSTRUCTION.

2.00 **TIMBER CONSTRUCTION**

- 2.01 ALL TIMBER SHALL BE SOUTHERN PINE. SELECT STRUCTURAL GRADE, DRESSED, AND GRADED IN ACCORDANCE WITH SPIB'S "GRADING RULES" AND WITH A MOISTURE CONTENT OF 19 PERCENT AT TIME OF DELIVERY TO THE PROJECT SITE.
- 2.02 ALL LUMBER AND TIMBER SHALL BE TREATED IN ACCORDANCE WITH AWP A C2 AS LISTED IN AWP A P5 TO A RETENTION LEVEL AS SHOWN:  
ALL TIMBER \_\_\_\_\_ 2.5 PCF, ACQ
- 2.03 ALL TIMBER HARWARE SHALL BE HOT DIPPED GALVANIZED IN ACCORDANCE WITH ASTM A153.
- 2.04 ALL PLATE WASHERS SHALL CONFORM WITH ASTM A36, 6ALV.
- 2.05 ALL BOLTS SHALL CONFORM WITH ASTM A307. ALL NUTS SHALL CONFORM WITH ASTM A563. ALL WASHERS SHALL CONFORM WITH ASTM F843.
- 2.06 DRILL ALL HOLES STRAIGHT AND PERPENDICULAR TO THE BEARING SURFACE.
- 2.07 UNLESS NOTED OTHERWISE, USE ONLY FULL LENGTH TIMBERS.
- 2.08 COUNTERBORE HOLES FOR BOLTS FOR COUNTER SINKING BOLT HEADS AND WASHERS.
- 2.09 WHERE PRACTICAL, CUT TIMBER TO REQUIRED LENGTH WITH STRAIGHT CUTS AND NO SPLINTERED EDGES, AND DRILL HOLES PRIOR TO PRESERVATIVE TREATMENT TO MINIMIZE TREATING CUTS AND HOLES IN THE FIELD.
- 2.10 PRIOR TO ERECTION OF TIMBERS, COAT ALL CUT, BORED, DAPPED AND DAMAGED TIMBER SURFACES IN ACCORDANCE WITH AWP A M3.
- 2.11 ERECT TIMBER WORK PLUMB AND LEVEL WITH TIGHT JOINTS BETWEEN ALL MEMBERS.
- 2.12 TIGHTEN BOLTS SUFFICIENTLY TO BRING ALL BEARING SURFACES INTO CONTACT.
- 2.13 COAT END GRAIN OF ALL EXPOSED VERTICAL TIMBERS WITH PRESERVATIVE.
- 2.14 EXERCISE CARE WHEN HANDLING TIMBER TO AVOID SURFACE AND STRUCTURAL DAMAGE. DO NOT USE CANT HOOKS, DOGS, OR PIKE POLES FOR HANDLING TIMBER
- 2.15 STORE TIMBER UNDER COVER, ABOVE GROUND AND KEEP FREE FROM DIRT, GREASE OR OTHER FOREIGN MATTER. STACK TIMBER IN A MANNER THAT WILL PREVENT LONG TIMBERS FROM SAGGING OR BECOMING CROOKED.
- 2.16 ALL EXISTING TIMBER STAIR COMPONENTS THAT ARE TO BE REMOVED SHALL BE DISPOSED OF OFF-SITE BY THE CONTRACTOR.

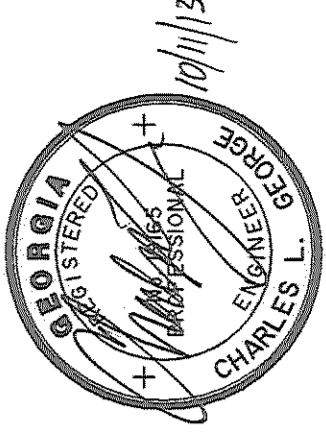

NO.	REVISIONS	BY	DATE

**THOMAS & HUTTON**  
 Engineering | Surveying | Planning | GIS | Consulting  
 50 Park of Commerce Way • PO Box 2727  
 Savannah, GA 31402-2727 • 912.234.5300  
 www.thomasandhutton.com  
 Brunswick, GA | Charleston, SC | Myrtle Beach, SC | Wilmington, NC

**CHATHAM COUNTY PUBLIC WORKS**  
 CHATHAM COUNTY, GEORGIA  
**TYBEE PIER STAIR REPLACEMENT**  
**GENERAL NOTES**

JOB NO:	J-23492.0000
DATE:	11/01/12
DRAWN:	JWR
DESIGNED:	CLG
REVIEWED:	CLG
APPROVED:	CLG
SCALE:	AS SHOWN

**S0.1**

W:\33492 - Tybee Pier Replacement\Drawings\33492 - S1.1.dwg - DWG PLT 200 - 9/23/11 AM

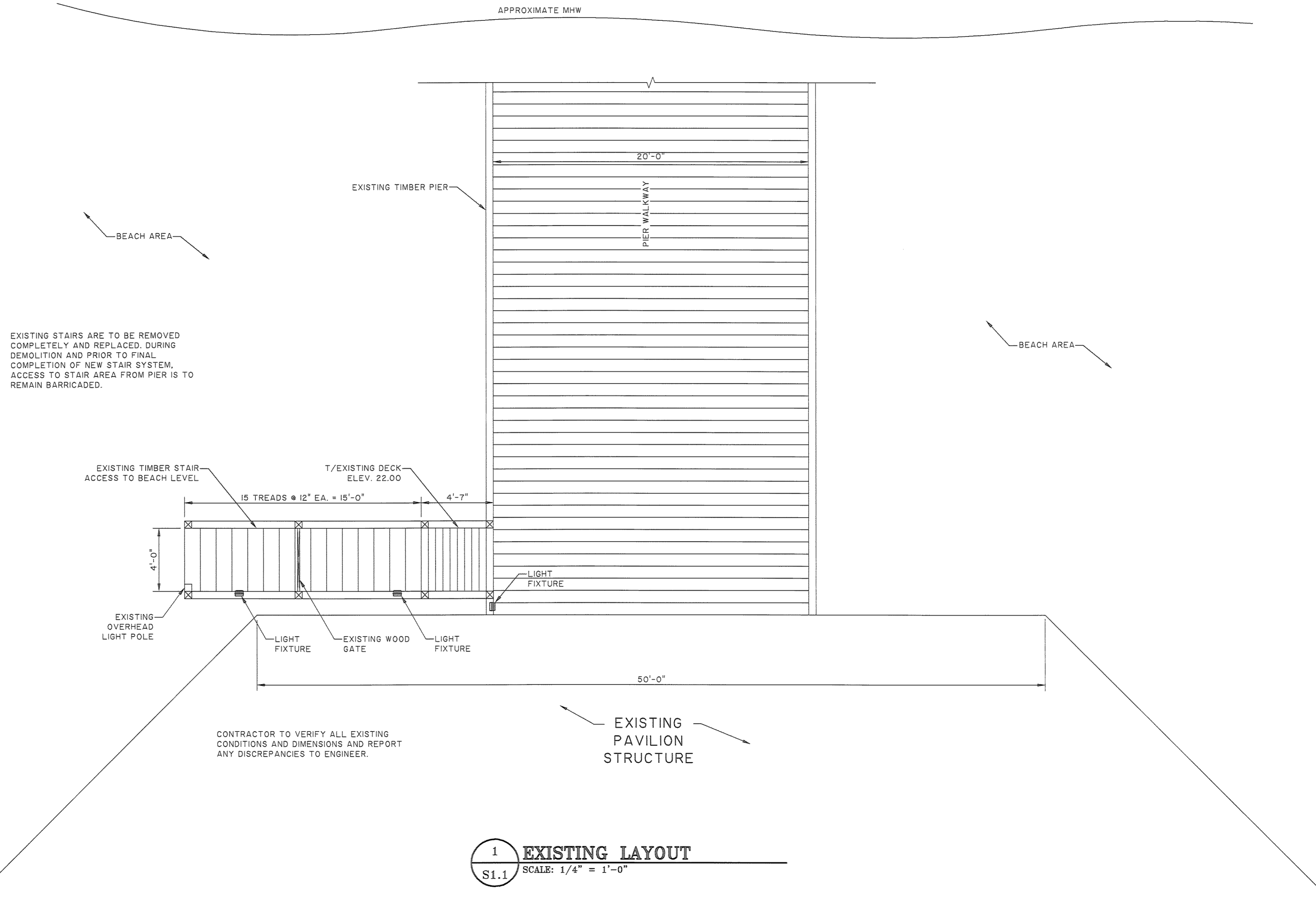
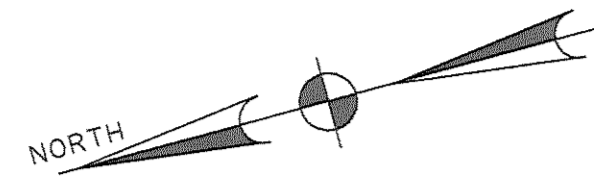

1  
S1.1 **EXISTING LAYOUT**  
SCALE: 1/4" = 1'-0"

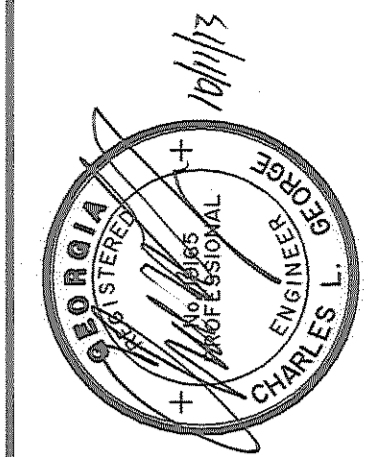

NO.	REVISIONS	BY	DATE

**THOMAS & HUTTON**  
Engineering | Surveying | Planning | GIS | Consulting  
50 Park of Commerce Way • PO Box 2727  
Savannah, GA 31402-2727 • 912.234.5300  
www.thomasandhutton.com  
Brunswick, GA | Charleston, SC | Myrtle Beach, SC | Wilmington, NC

**CHATHAM COUNTY PUBLIC WORKS**  
CHATHAM COUNTY, GA.  
TYBEE PIER STAIR REPLACEMENT  
**EXISTING LAYOUT**

JOB NO:	J-23492.0000
DATE:	12/28/11
DRAWN:	JWR
DESIGNED:	CLG
REVIEWED:	CLG
APPROVED:	CLG
SCALE:	AS SHOWN

**S1.1**

V:\2020 - 2024\PROJECTS\TYBEE PIER\TYBEE PIER.dwg - 12/28/2024

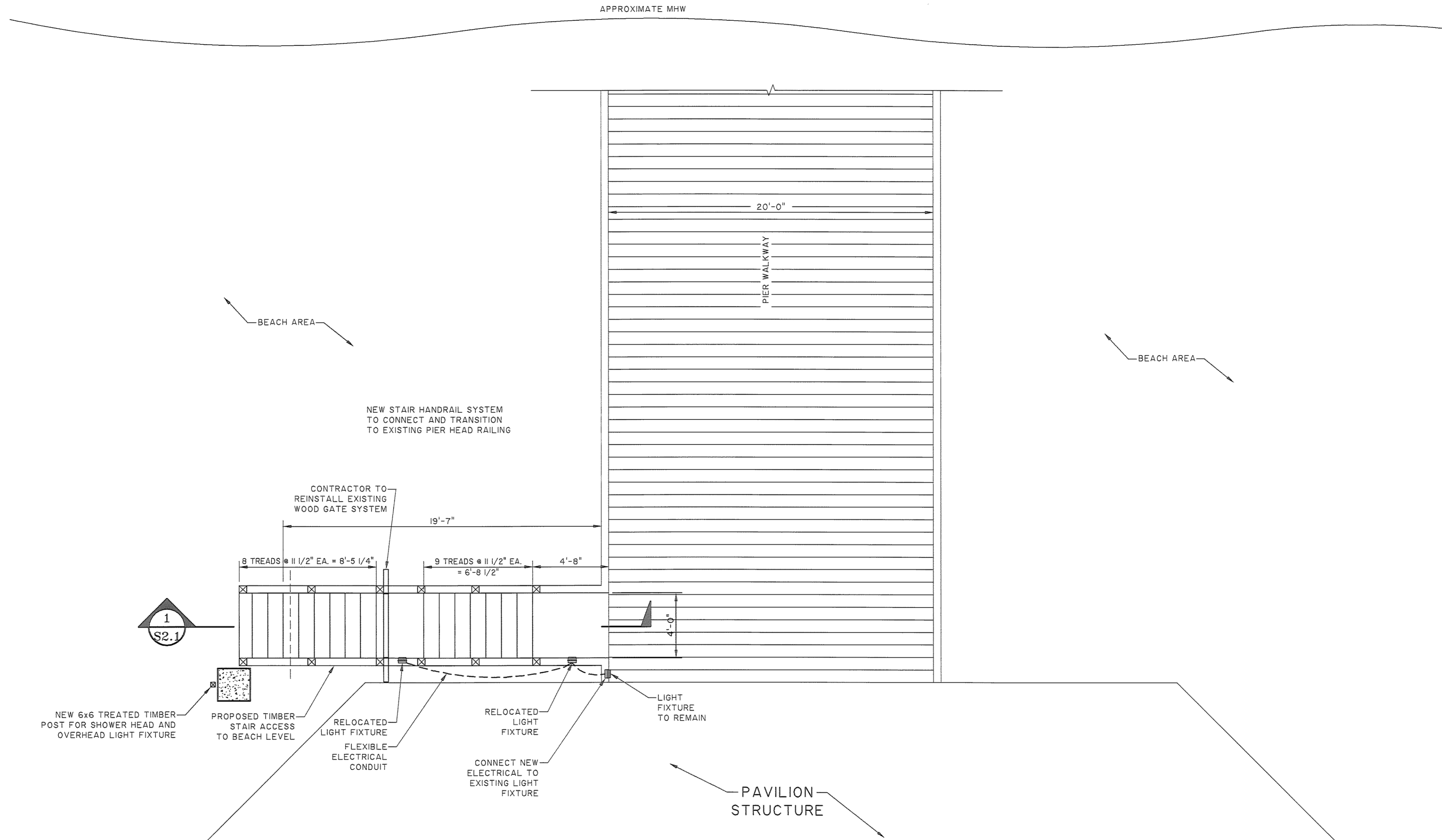

**1**  
S1.2 **PROPOSED LAYOUT**  
SCALE: 1/4" = 1'-0"

**NOTE:**  
1. NEW LIGHT FIXTURES TO MATCH EXISTING (RIM 6 LF-60, TO HPS/BL-P)  
2. THE INTENT FOR THE ELECTRICAL LIGHTING AND WATER LINE CONNECTION IS TO REPLACE THE EXISTING SYSTEM IN KIND AND SIMILAR FUNCTION. CONTRACTOR IS TO INSTALL NEW SYSTEM WITH CONNECTION TO EXISTING ELECTRICAL AND WATER SUPPLY LINES AS REQUIRED.

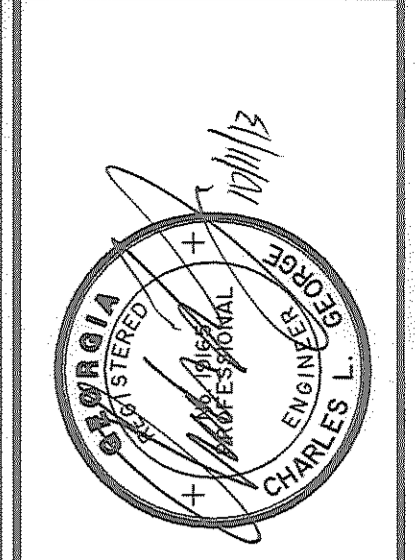

NO.	REVISIONS	BY	DATE

**THOMAS & HUTTON**  
Engineering | Surveying | Planning | GIS | Consulting  
50 Park of Commerce Way • PO Box 2727  
Savannah, GA 31402-2727 • 912.234.5300  
www.thomasandhutton.com  
Brunswick, GA | Charleston, SC | Myrtle Beach, SC | Wilmington, NC

**CHATHAM COUNTY PUBLIC WORKS**  
CHATHAM COUNTY, GA.  
**TYBEE PIER STAIR REPLACEMENT**  
**PROPOSED LAYOUT**

JOB NO:	J-23492.0000
DATE:	12/28/24
DRAWN:	JWR
DESIGNED:	CLG
REVIEWED:	CLG
APPROVED:	CLG
SCALE:	AS SHOWN

**S1.2**

W:\32422 - Tybee Pier Replacement\32422.dwg - 04/28/20 - 0.00/0.00

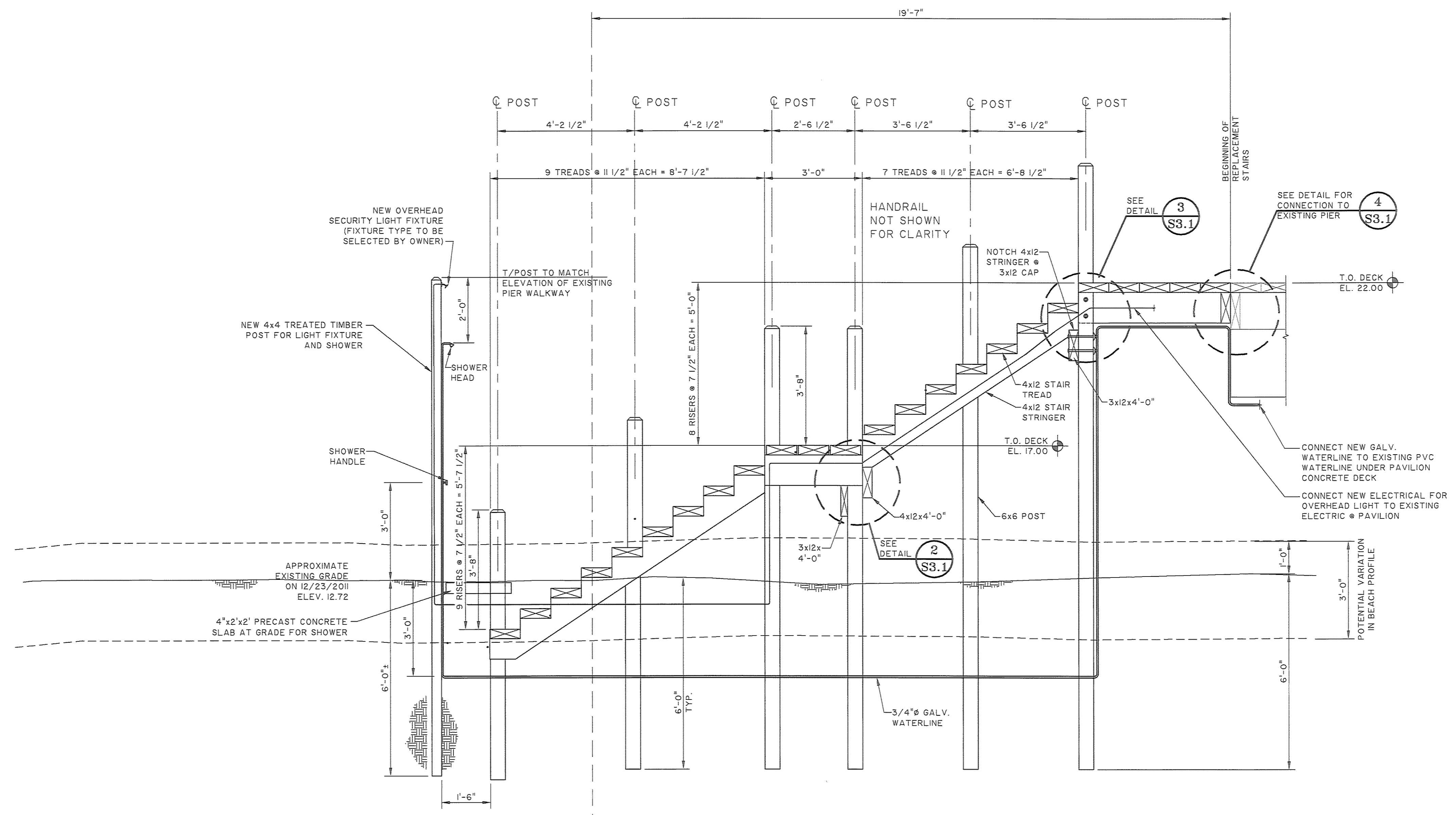

**1 STAIR ELEVATION**  
 S2.1 SCALE: 1/2" = 1'-0"

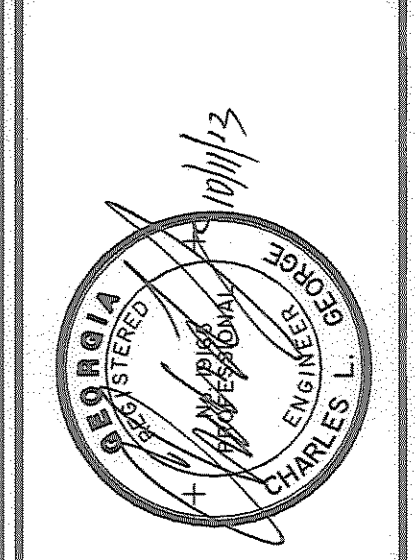

NO.	REVISIONS	BY	DATE

**THOMAS & HUTTON**  
 Engineering | Surveying | Planning | GIS | Consulting  
 50 Park of Commerce Way • PO Box 2727  
 Savannah, GA 31402-2727 • 912.234.5300  
 www.thomasandhutton.com  
 Brunswick, GA | Charleston, SC | Myrtle Beach, SC | Wilmington, NC

**CHATHAM COUNTY PUBLIC WORKS**  
 CHATHAM COUNTY, GA.  
**TYBEE PIER STAIR REPLACEMENT**  
**ELEVATIONS**

JOB NO:	J-23492.0000
DATE:	12/28/11
DRAWN:	JWR
DESIGNED:	CLG
REVIEWED:	CLG
APPROVED:	CLG
SCALE:	AS SHOWN

**S2.1**

W:\31302 - 1544 PIER REPLACEMENT\31302 - 01.dwg - DWG, 2011-10-20 9:20:07 AM

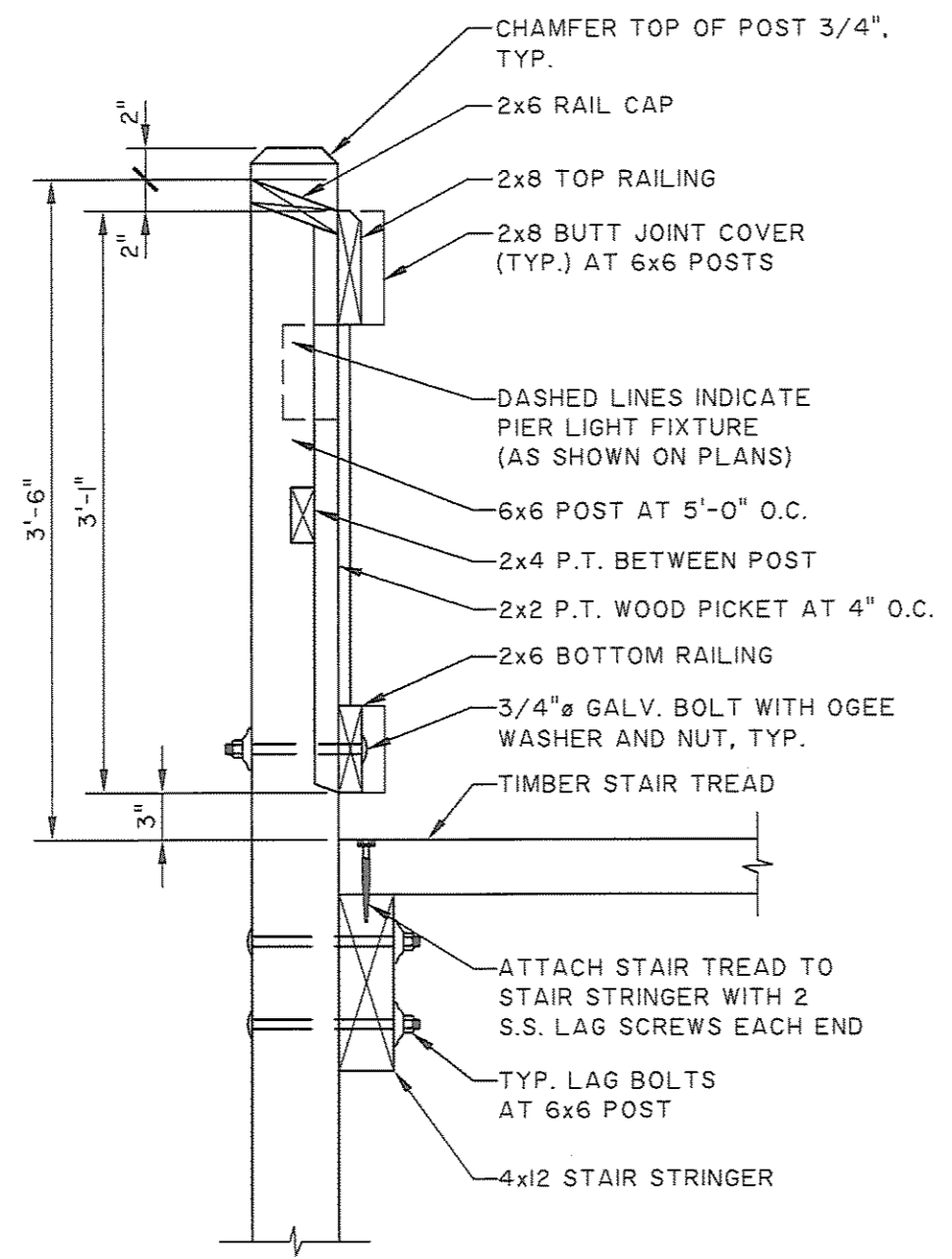

**1 HANDRAIL DETAIL**  
 S3.1 SCALE: 1" = 1'-0"

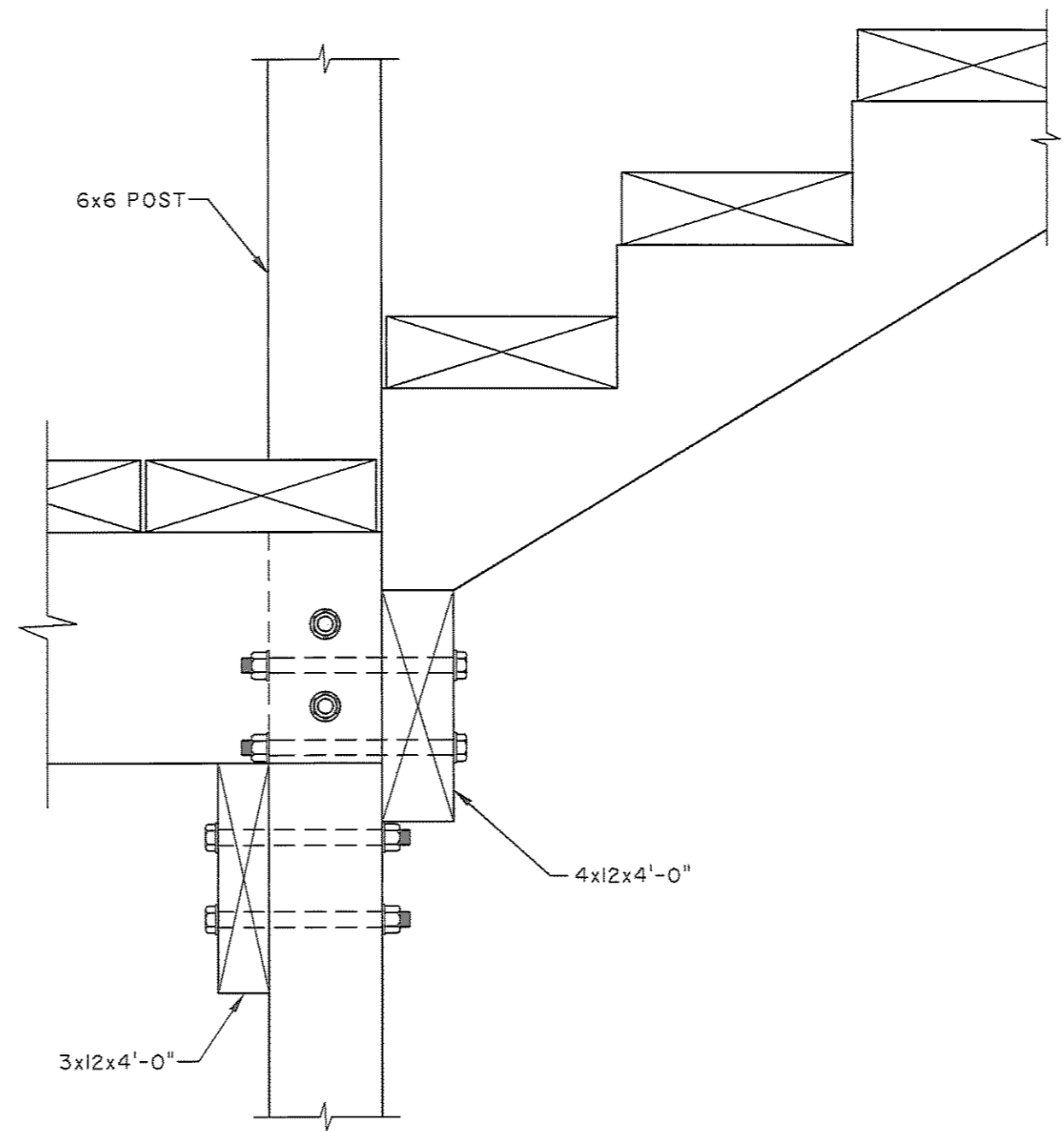

**2 DETAIL**  
 S3.1 SCALE: 1 1/2" = 1'-0"

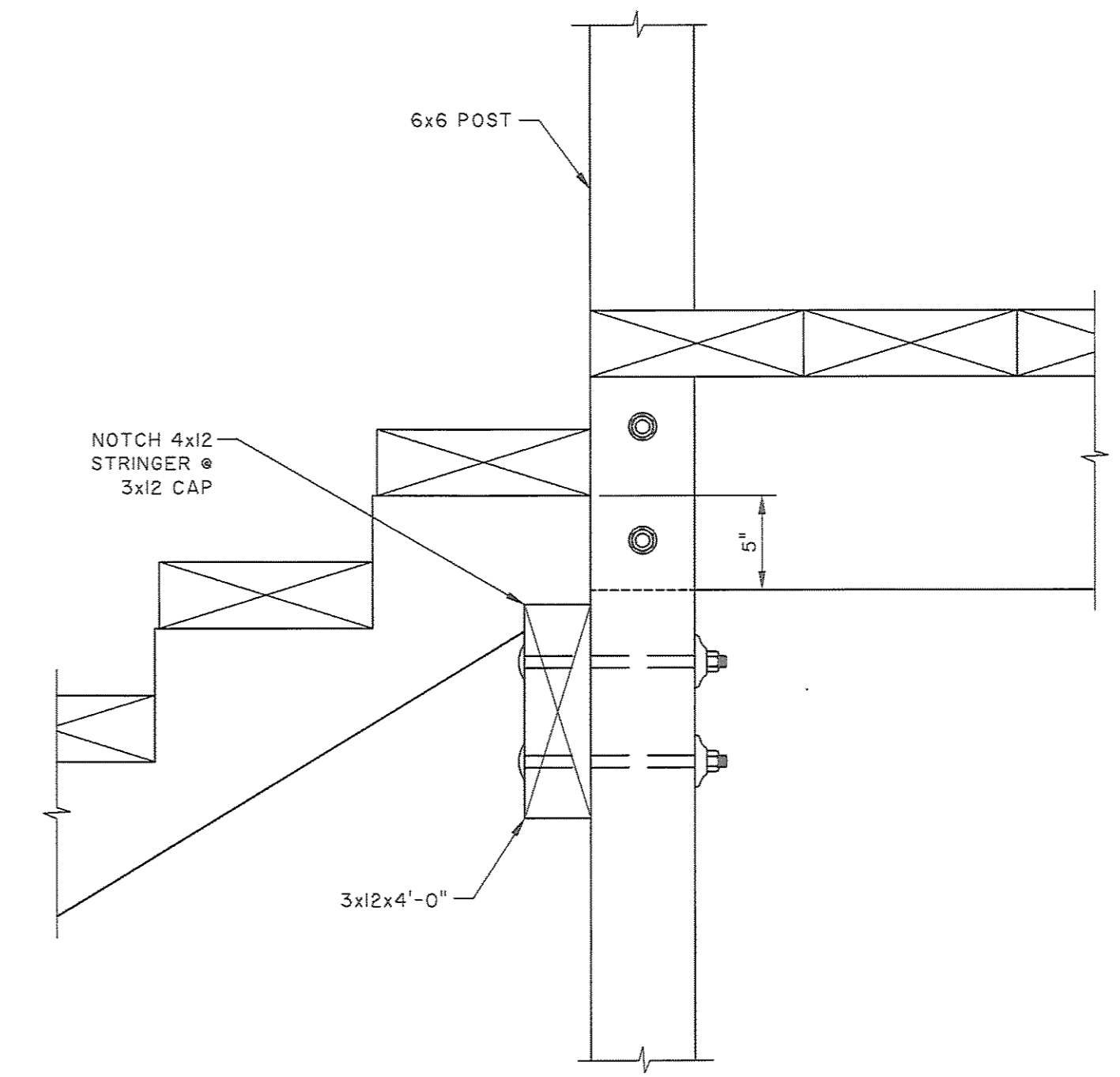

**3 DETAIL**  
 S3.1 SCALE: 1 1/2" = 1'-0"

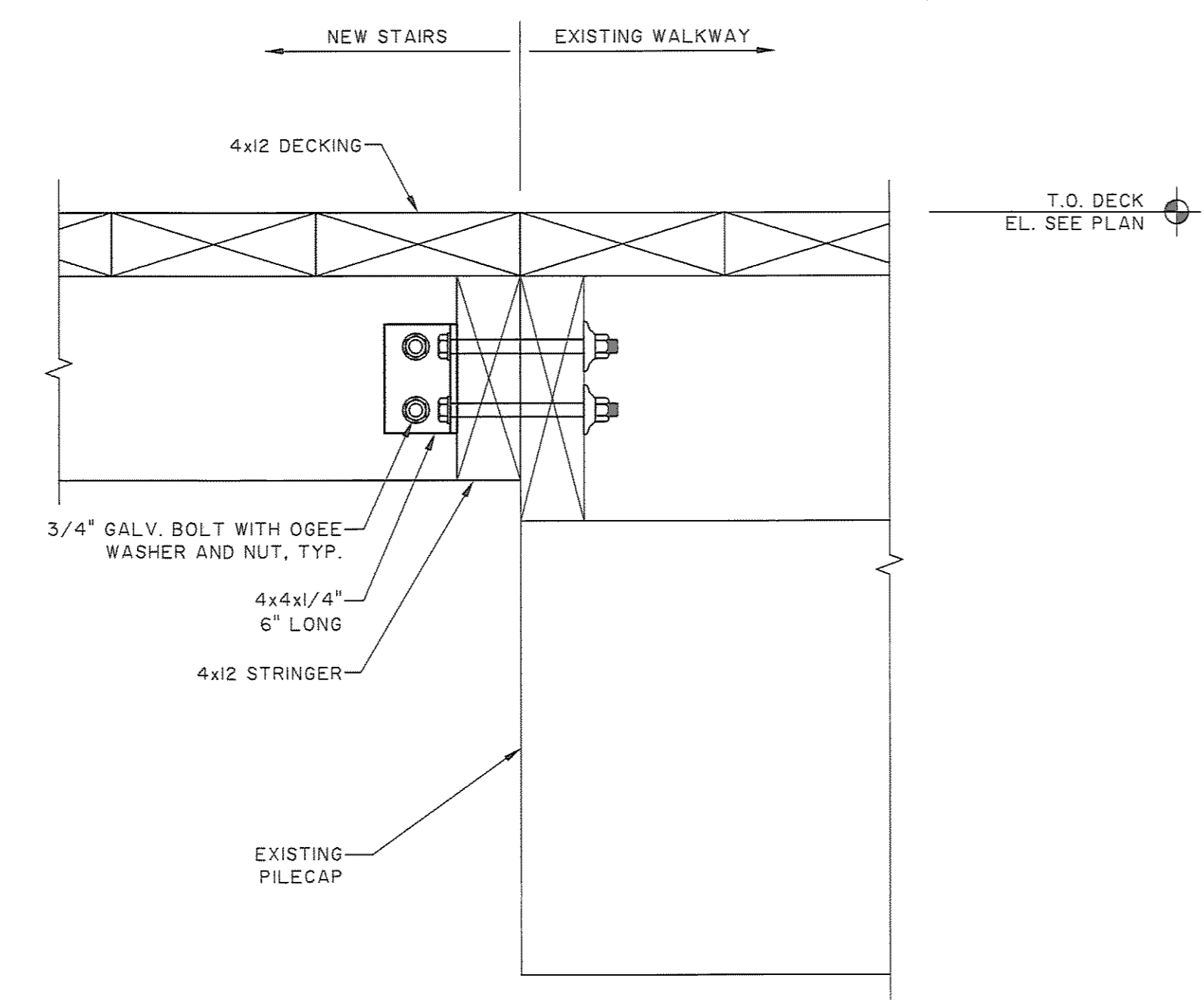

**4 DETAIL**  
 S3.1 SCALE: 1 1/2" = 1'-0"

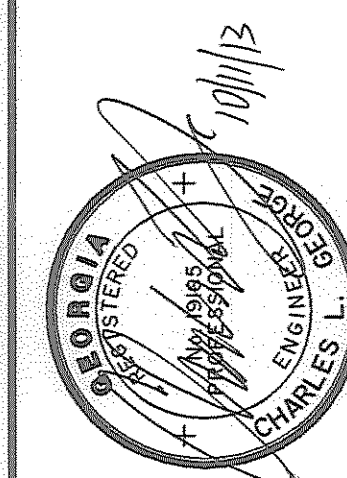

NO.	REVISIONS	BY	DATE

**THOMAS & HUTTON**  
 Engineering | Surveying | Planning | GIS | Consulting  
 50 Park of Commerce Way • PO Box 2727  
 Savannah, GA 31402-2727 • 912.234.5300  
 www.thomasandhutton.com  
 Brunswick, GA | Charleston, SC | Myrtle Beach, SC | Wilmington, NC

**CHATHAM COUNTY PUBLIC WORKS**  
 CHATHAM COUNTY, GA.  
 TYBEE PIER STAIR REPLACEMENT  
**DETAILS**

JOB NO:	J-23492.0000
DATE:	12/28/11
DRAWN:	JNR
DESIGNED:	CLG
REVIEWED:	CLG
APPROVED:	CLG
SCALE:	AS SHOWN

**S3.1**